

# Excelair

By Excelsior

## Instruction Manual



**Model: ETF 45RI**

# TABLE OF CONTENTS

|                             |         |
|-----------------------------|---------|
| 1. TOWER FAN PARTS          | PAGE 6  |
| 2. ASSEMBLY INSTRUCTIONS    | PAGE 7  |
| 3. OPERATING INSTRUCTIONS   | PAGE 8  |
| 4. FND DISPLAY INSTRUCTIONS | PAGE 9  |
| 5. REMOTE GUIDLINES         | PAGE 9  |
| 6. BATTERY GUIDELINES       | PAGE 10 |
| 7. SPECIFICATIONS           | PAGE 10 |
| 8. CLEANING INSTRUCTIONS    | PAGE 11 |
| 9. STORAGE                  | PAGE 12 |
| 10. CARE & MAINTENANCE      | PAGE 13 |
| 11. WARRANTY                | PAGE 13 |

**Read all these instructions before attempting to operate this product and save these instructions.**

- Check the voltage indicated on the rating plate. This tool is designed for a 220-240V/50Hz electric supply.
- Do not use electrical extension cord with this fan.
- Do not place your fingers through the front case. Do not let children put any foreign objects into the front case.
- Do not let hair, net curtains, tablecloth, clothes or curtains next to the openings of the fan. They could be drawn into the fan, causing damage or injuries.
- Do not use fan if the cord or plug are damaged, or if the fan is dropped or have been damaged in any way.
- Periodically check the electric cable of this fan. If the electric cable is damaged, it must be replaced by the manufacturer, its after-sales service or by a similar qualified person in order to avoid a danger.
- Do not use this fan outside.
- Do not use this fan in a damp area such as bathroom.
- Do not use this fan on a window.
- Do not use this fan with any semi-conductors speed control.
- The fan should not be operate without a base nor used laying on its side.

- Do not place the electrical cord under a cover. Do not overlay the cord but place the cord in an area where there are no risks to stumble over.
- The fan must always be unplugged when not operating. To unplug the fan, all the switches must be on the position "OFF", and then the plug could be disconnected.
- Do not operate the fan in an area where gasoline is used or stocked, painting or such flammable liquids.
- Use this fan only as described in this manual.
- No part of this fan must be replaced by the user. If you need maintenance take the fan back to your place of purchase.
- If the supply cord is damaged, it must be replaced by the manufacturer or its service agent or a similarly qualified person in order to avoid a hazard.
- The fan **MUST NOT** be earthed.

**Keep electrical appliances out of reach from Children. Do not let them use the appliances without supervision.**

**NOTE:** There are no serviceable parts in this unit. Do not attempt to disassemble. **WARNING:** Never use this fan with any solid-state speed control device. Doing so will create fire and/or shock hazards.

# 1. TOWER FAN PARTS

1. Top control panel
2. FND Display
3. Front cover
4. Back cover
5. Grille
6. Column
7. Base
8. Remote control

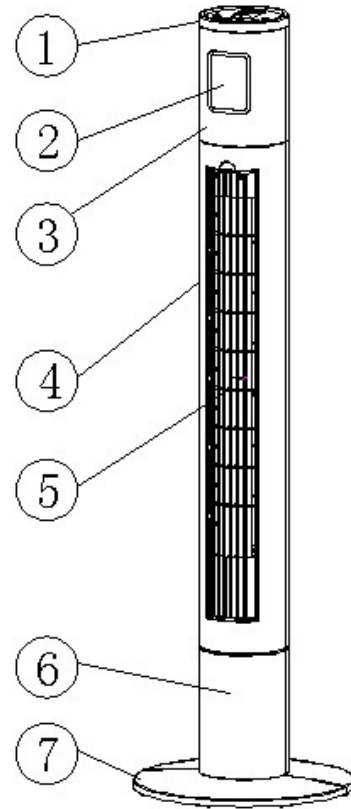

**CAUTION:** THIS FAN MUST OPERATE IN THE UPRIGHT POSITION ONLY. DO NOT LAY FAN ON ITS SIDE OR IN ANY OTHER POSITION. DOING SO MAY CAUSE DAMAGE TO THE FAN AND/OR PERSONAL PROPERTY. DO NOT USE THIS FAN WITHOUT ITS BASE.

## 2. ASSEMBLY INSTRUCTIONS

1. Remove all items of packing from the tower fan.
2. Pass the power cord through the middle of the two base pieces
- 3: Position base piece onto the support posts of the other base piece to create the base assembly.
- 4: Turn the tower body upside down, position the base assembly onto the pedestal tube. Ensure that the pedestal tube is sitting flush in the base assembly.
- 5: Screw the base assembly onto the pedestal tube with the supplied screws.
- 6: Position the power cord into the provided cord track in the rear base.
- 7: Turn the tower fan back to upright position. It is now ready for use

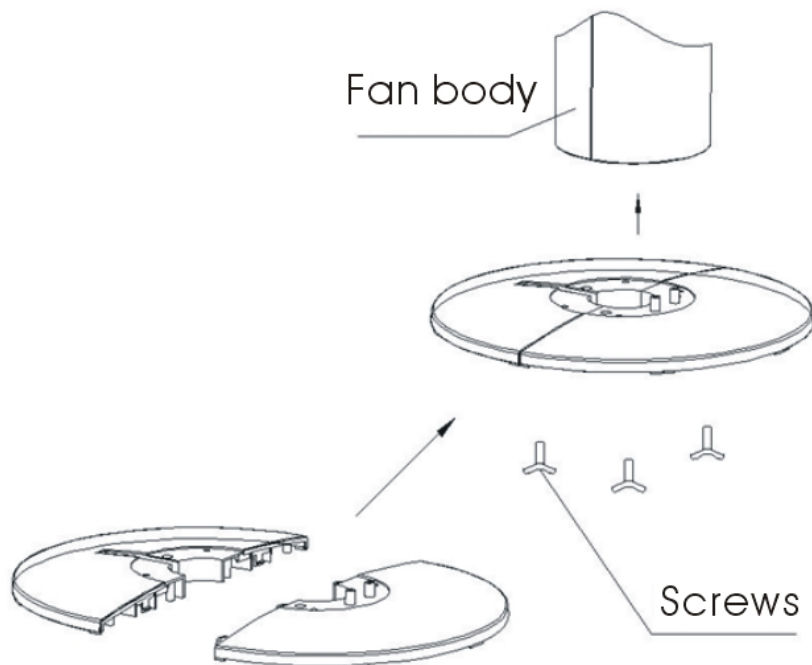

### 3. OPERATING INSTRUCTIONS

- 1: Use in a dry place, free of excessive humidity and water.
- 2: This unit can be operated by the control panel on the fan or by remote control in the same manner.

#### TOP CONTROL PANEL

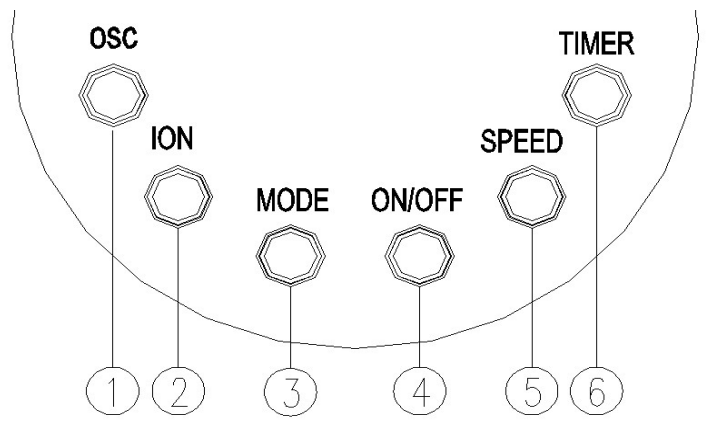

**On/Off:**

Press this button to turn the fan on or off.

Press it, product will start at low speed. Press again, the product will stop.

**Osc:** Press the oscillation button to activate the oscillation function for widespread breeze distribution. Press again to turn the oscillation function off.

**Timer:** Press this button to activate the timer – off function. Each time the button is pressed the timer will be increased by 1 hour up to a maximum of 12 hours.

**Speed:** Choose from 3 comfort settings (HIGH, MED, LOW) by pressing this button until the speed you want is indicated on the FND display.

**Mode:** Choose from 3 different breeze patterns (Sleep, Nature, Normal) by pressing this button until the type of breeze desired is indicated on the FND display.

**Ion:** Press this button, product will clear and fresh the air. Press again to stop Ion function

## 4. FND DISPLAY

- 1: Ion
- 2: Sleep wind
- 3: Natural wind
- 4: Room Temperature  
and Timer Display
- 5: Oscillation
- 6: Speed

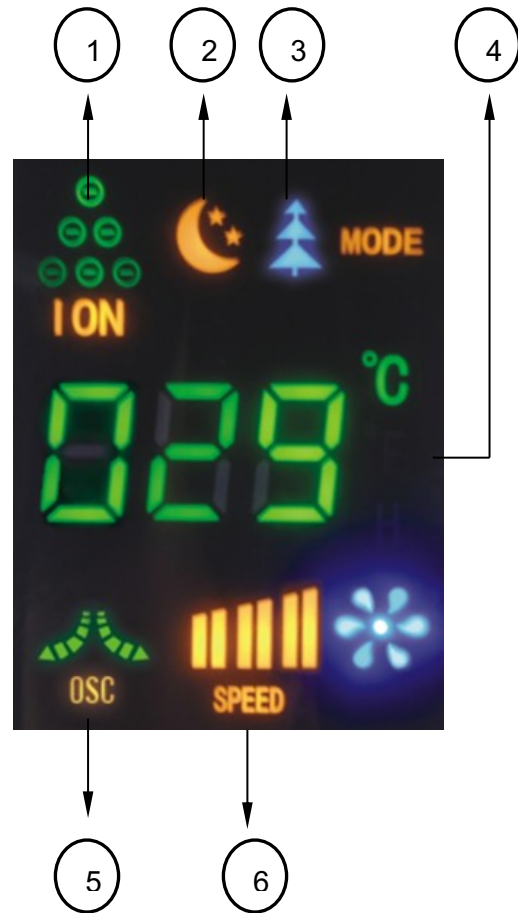

## 5. GUIDELINES FOR USING THE REMOTE CONTROL

- The remote control must be pointed towards the receiver on the fan in order to work.
- Do not block the line of sight between remote control and the receiver.
- Handle the remote control with care. Do not drop the remote control.

## **6. GUIDELINES FOR USE OF BATTERIES**

- If the remote control is not used for a long period of time, remove the batteries from the battery compartment.
- The remote control uses two AAA batteries, both of which should be new and replaced at the same time when they run out.
- Clean battery contacts and also those of the device prior to battery installation
- Ensure the batteries are installed correctly with regard to polarity, matching +/- sides of the battery to corresponding indications on the remote control.
- Remove used and dead/discharged batteries promptly.

## **7. SPECIFICATIONS**

Model Number: ETF-45RI

Voltage: 220-240V / 50Hz

Wattage: 45 W

**CAUTION: TO PREVENT ELECTRICAL SHOCK, MATCH WIDE BLADE OF PLUG TO WIDE SLOT, FULLY INSERT.**

## 8. CLEANING INSTRUCTIONS

1. Always disconnect the cord from the electrical outlet before cleaning your fan.
2. Dust may be removed by using a vacuum cleaner along the back of the fan where the plastic grille covers the air intake.
3. Wipe the exterior surfaces of the fan occasionally with a damp cloth (not dripping wet) and dry thoroughly with a soft dry cloth before operating the fan.
4. Do not use harsh cleaners or materials to clean this unit, doing so will cause damage.
- 5: Unscrew the screw in front of fan grille, open the grille to clean the fan wheel softly. Please see below picture.

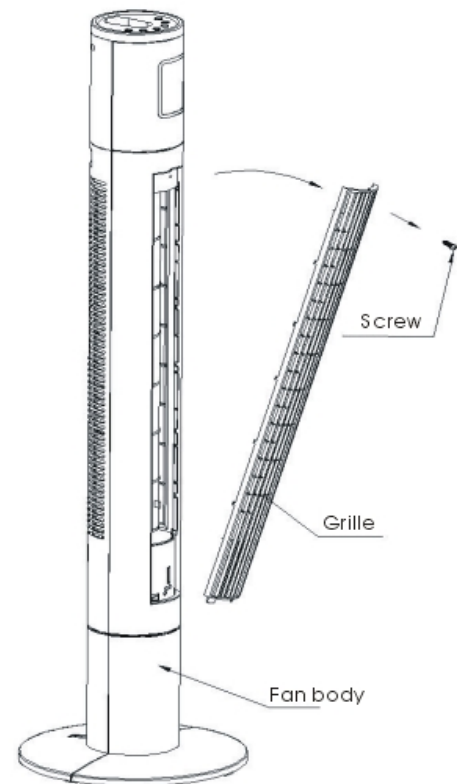

**CAUTION:**

DO NOT ALLOW WATER TO RUN INTO THE INTERIOR OF THE FAN AS THIS COULD CREATE A FIRE OR ELECTRIC SHOCK HAZARD. THE FAN MOTOR IS FACTORY LUBRICATED FOR LIFE AND WILL REQUIRE NO FURTHER LUBRICATION. NO OTHER USER MAINTENANCE IS REQUIRED OR RECOMMENDED. IF SERVICE IS REQUIRED, PLEASE CONTACT HONEYAIR AUSTRALIA.

**9. STORAGE**

1. Follow cleaning instructions 1-4 above.
2. Retain the original packaging to store your fan.
3. Always store in a dry place.
4. Never store while still plugged in.
5. Never wrap cord tightly around the fan or put any stress on the cord where it enters the fan as it could cause the cord to fray or break.

## **10. CARE AND MAINTENANCE**

- 1: Always disconnect the cord from the electrical outlet when cleaning your fan.
- 2: Light accumulated dust may be removed from the fan with a soft cloth or vacuum cleaner using the dusting brush attachment.
- 3: Wipe the exterior surfaces of the fan occasionally with a cloth moistened (Not dripping wet) with a mild soap solution. Dry the case thoroughly with a soft dry cloth before operating the fan.
- 4: Avoid the use of gasoline, benzene, thinner etc as they may result in damage to the fan.
- 5: Store the fan in a clean dry place when not in use.

## **11. WARRANTY**

The Excelair ETF45RI Tower Fan is under warranty for a period of 12 months from date of purchase. If unit is deemed to be faulty, please return to place of purchase and it will be replaced during the 12 month warranty period.

# **Excelair**

By Excelsior

For any queries or assistance call  
Customer Service  
(Australia Only)  
**1300 174 876**  
Hours of operation:  
Monday to Friday 8am - 5pm EST

IMPORTANT: RETAIN THESE INSTRUCTIONS FOR FUTURE USE.

Excelair™ is a trademark of Sitro Group Australia  
[www.excelsiorproducts.com.au](http://www.excelsiorproducts.com.au)