

# ExCelair

By Excelsior

Scan QR Code  
for WiFi Setup



EPA58023W

**Portable Air  
Conditioner**

**INSTRUCTIONS**

**Important: Retain these instructions for future use.**

## 24 MONTH WARRANTY

The warranty is not transferable to a subsequent purchaser if the appliance is sold by the original purchaser during the warranty period.

If a warranty fault appears within the warranty period, S.G.A. reserves the right to replace or repair the appliance.

In the event that S.G.A. chooses to replace the appliance, this original warranty will expire at the original date.

If the appliance includes various accessories or components, only the defective accessory or component will be replaced or repaired.

S.G.A. Reserves the right to replace defective parts of the appliance with parts and components of similar quality, grade and composition where an identical part or component is not available.

Appliances presented for repair may be replaced by refurbished appliances of the same type rather than being repaired. Refurbished parts may be used to repair the appliances.

To make a warranty claim, first contact S.G.A.'s Customer Service Line on the contact number below or visit [sitro.com.au/support](http://sitro.com.au/support).

The purchase receipt for this appliance is to be retained and must be presented if making claim under the terms of this S.G.A. warranty.

Warranty repairs are free of charge, provided the appliance is delivered to our Service Department at 33-35 Lionel Road, Mt Waverley, Victoria, 3149 or to one of our Authorised Service Agents.

If a warranty fault is found the freight cost will be credited to the owner. If no fault is found the appliance will be returned and any costs associated with the service will be charged to the owner.

Appliances sent freight forward will not be accepted. In most cases the defective accessory or component only will need to be returned. The appliance or part of the appliance being returned must be adequately protected in a box.

S.G.A. will not be responsible for any in-transit loss or damage.

This warranty does not apply to any defect, deterioration, loss, injury or damage occasioned by or as a result of misuse or abuse, negligent handling or storage, normal wear and tear or if the appliance has not been installed and used in accordance with S.G.A.'s instructions, recommendations and specifications or if the appliance has been subjected to abnormal conditions. The warranty does not apply to blockages caused by insects or living organisms, as well as incorrectly installed ducts.

The warranty is void if there is evidence of the appliance being tampered with by unauthorised persons. The warranty does not extend to installation or disconnection costs.

Our goods come with guarantees that cannot be excluded under the Australian Consumer Law. You are entitled to a replacement or refund for a major failure and for compensation for any other reasonably foreseeable loss or damage. You are also entitled to have the goods repaired or replaced if the goods fail to be of acceptable quality and the failure does not amount to a major failure. The benefits of this warranty are in addition to any rights and remedies imposed by Australian State and Federal legislation that cannot be excluded.

### Appliance approved for indoor use only

For warranty claims, service, spare parts or appliances information in Australia, please call SITRO GROUP AUSTRALIA Pty Ltd on the Customer Service Line 1300 174 876.

A receipt or proof of purchase is required and must be kept for your records.

### CONTACT DETAILS

Sitro Group Australia Pty Ltd  
33-35 Lionel Road, Mt. Waverley  
Victoria 3149, Australia  
Tel (+613) 9543 9533  
Fax (+613) 9543 9839  
[sitro.com.au/support](http://sitro.com.au/support)  
[service.group@sitro.com.au](mailto:service.group@sitro.com.au)

**For any queries or assistance call**



**Customer Service**

**Australia Only**

**1300 174 876**

Hours of operation:

Monday to Friday 8am - 5pm EST

**Do not return to place of purchase.**

# INSTALLATION - GENERAL INFORMATION

## INDOOR USE ONLY



Read all instructions before installing and operating this Appliance.

This appliance is designed for indoor use only. Do not install, operate or store this appliance in a room smaller than 11m<sup>2</sup>.

### WHAT IS AN INDOOR AREA

- FOR INDOOR USE ONLY.
- The mains supply must conform to the specification shown on the rating label on the back of the appliance.
- Do not use this appliance in a cabinet, confined spaces or on boats, caravans or similar locations.
- Do not use this appliance in close proximity to swimming pools
- Stand the appliance upright for at least 12 hours to allow the compressor oil to settle before connecting to the mains supply after transporting or when the appliance has been tilted (for example, while cleaning)
- Only use the appliance in the upright position on a flat level surface (even during transport!) and at least 50cm from any objects.
- Do not use the appliance in a potentially explosive environment containing combustible liquids, gases or dusts.
- Do not use the appliance in the vicinity of flammable or explosive substances or fuels. Never use any paint, cleaning sprays, anti-insect sprays or similar near the appliance; this could deform the plastic or cause electrical damage.
- Ensure that there is at least 50cm between the sides of the appliance and any flammable, heating materials.
- Do not place objects on the appliance or restrict air inlet/outlet.
- Avoid splashing any type of liquid onto this appliance
- Closely supervise any children and pets when the appliance is in use.
- This appliance is not intended for use by persons (including children) with reduced physical, sensory or mental capabilities, or lack of experience and knowledge, unless they have been given supervision or instruction concerning use of the appliance by a person responsible for their safety. Children should be supervised to ensure that they do not play with the appliance.
- Cleaning and user maintenance shall not be made by children without supervision.
- Switch off and unplug the appliance when not in use.
- Never leave a functioning appliance unsupervised.
- Do not pull the appliance along by the cord.
- Avoid over-twisting, coiling or pulling the power cord.
- Make sure that the plug and socket remain visible and accessible at all the time.
- Do not use extension cords.
- IF THE SUPPLY CORD IS DAMAGED, IT MUST BE REPLACED BY THE MANUFACTURER, ITS SERVICE AGENT OR SIMILARLY QUALIFIED PERSONS IN ORDER TO AVOID A HAZARD.
- THE MAINS SUPPLY MUST CONFORM TO THE SPECIFICATION SHOWN ON THE RATING LABEL AT THE BACK OF THE APPLIANCE.
- **The appliance shall be installed in accordance with national wiring regulations.**
- Do not exceed the recommended room size for max. efficiency.
- Close the doors and windows.
- Keep curtains or blinds closed during the sunniest hours of the day.
- Keep filters clean.
- Once room has reached the desired conditions, reduce the setting for temperature and ventilation, it maybe necessary to periodically adjust the temperature and ventilation settings to suit personal preferences for the environment.
- Servicing shall be performed only as recommended by the manufacturer.



### Electrical Data IMPORTANT SAFETY RULES

This appliance is fitted with a sealed electrical connection plug that is compatible with the mains power supply for Australia / New Zealand and meets the requirements of Australian Standards. This appliance must be connected to a supply voltage that is equal to that stated on the rating label. If the mains power connection plug or power cord becomes damaged it must be replaced with a complete assembly that is identical to the original, and this must be replaced by an authorised service centre. Always follow the Australian / New Zealand requirements for connection to the mains supply. If in doubt always consult a qualified electrician.

## GENERAL INFORMATION

1. The appliance shall be stored so as to prevent mechanical damage from occurring
2. Every working procedure (Such as below) that affects safety means shall only be carried out by competent persons.
  - breaking into the refrigerating circuit;
  - opening of sealed components;
  - opening of ventilated enclosures.
3. Prior to beginning work on systems containing flammable refrigerants, safety checks are necessary to ensure that the risk of ignition is minimised.
4. For repair to the refrigerating system, below shall be completed prior to conducting work on the system.
  - A. Work shall be undertaken under a controlled procedure so as to minimise the risk of a flammable gas or vapour being present while the work is being performed.
  - B. All maintenance staff and others working in the local area shall be instructed on the nature of work being carried out. Work in confined spaces shall be avoided.
  - C. The area shall be checked with an appropriate refrigerant detector prior to and during work, to ensure the technician is aware of potentially toxic or flammable atmospheres. Ensure that the leak detection equipment being used is suitable for use with all applicable refrigerants, i.e. nonsparking, adequately sealed or intrinsically safe.
  - D. If any hot work is to be conducted on the refrigerating equipment or any associated parts, appropriate fire extinguishing equipment shall be available to hand. Have a dry powder or CO2 fire extinguisher adjacent to the charging area.
  - E. No person carrying out work in relation to a refrigerating system which involves exposing any pipe work shall use any sources of ignition in such a manner that it can lead to the risk of fire or explosion. All possible ignition sources, including cigarette smoking, should be kept sufficiently far away from the site of installation, repairing, removing and disposal, during which refrigerant can possibly be released to the surrounding space. Prior to work taking place, the area around the equipment is to be surveyed to make sure that there are no flammable hazards or ignition risks. "No Smoking" signs shall be displayed.
5. Ensure that the area is in the open or that it is adequately ventilated before breaking into the system or conducting any hot work. A degree of ventilation shall continue during the period that the work is carried out. The ventilation should safely disperse any released refrigerant and preferably expel it externally into the atmosphere.

6. Where electrical components are being changed, they shall be fit for the purpose and to the correct specification. At all times the manufacturer's maintenance and service guidelines shall be followed. If in doubt, consult the manufacturer's technical department for assistance.

The following checks shall be applied to installations using flammable refrigerants:

- the refrigerant charge is in accordance with the room size within which the refrigerant containing parts are installed;
  - the ventilation machinery and outlets are operating adequately and are not obstructed;
  - if an indirect refrigerating circuit is being used, the secondary circuit shall be checked for the presence of refrigerant;
  - marking to the equipment continues to be visible and legible. Markings and signs that are illegible shall be corrected;
  - refrigerating pipe or components are installed in a position where they are unlikely to be exposed to any substance which can corrode refrigerant containing components, unless the components are constructed of materials which are inherently resistant to being corroded or are suitably protected against being so corroded.
7. Repair and maintenance to electrical components shall include initial safety checks and component inspection procedures. If a fault exists that could compromise safety, then no electrical supply shall be connected to the circuit until it is satisfactorily dealt with. If the fault cannot be corrected immediately but it is necessary to continue operation, an adequate temporary solution shall be used. This shall be reported to the owner of the equipment so all parties are advised.

### Initial safety checks shall include:

- that capacitors are discharged: this shall be done in a safe manner to avoid possibility of sparking;
- that no live electrical components and wiring are exposed while charging, recovering or purging the system;
- that there is continuity of earth bonding.

8. Sealed electrical components shall not be repaired.
9. Check that cabling will not be subject to wear, corrosion, excessive pressure, vibration, sharp edges or any other adverse environmental effects. The check shall also take into account the effects of aging or continual vibration from sources such as compressors or fans.

- Under no circumstances shall potential sources of ignition be used in the searching for or detection of refrigerant leaks. A halide torch (or any other detector using a naked flame) shall not be used.

**The following leak detection methods are deemed acceptable for all refrigerant systems.**

Electronic leak detectors may be used to detect refrigerant leaks but, in the case of flammable refrigerants, the sensitivity can be inadequate, or can need re-calibration. (Detection equipment shall be calibrated in a refrigerant-free area.) Ensure that the detector is not a potential source of ignition and is suitable for the refrigerant used. Leak detection equipment shall be set at a percentage of the LFL of the refrigerant and shall be calibrated to the refrigerant employed, and the appropriate percentage of gas (25 % maximum) is confirmed.

Leak detection fluids are also suitable for use with most refrigerants but the use of detergents containing chlorine shall be avoided as the chlorine can react with the refrigerant and corrode the copper pipe-work.

**If a leak is suspected, all naked flames shall be removed/extinguished.**

If a leakage of refrigerant is found which requires brazing, all of the refrigerant shall be recovered from the system, or isolated (by means of shut-off valves) in a part of the system remote from the leak.

- When breaking into the refrigerant circuit to make repairs - or for any other purpose - conventional procedures shall be used. However, for flammable refrigerants it is important that best practice is followed since flammability is a consideration. The following procedure shall be adhered to:
  - safely remove refrigerant following local and national regulations;
  - evacuate;
  - purge the circuit with inert gas (optional for A2L);
  - evacuate (optional for A2L);
  - continuously flush with inert gas when using flame to open circuit;
  - open the circuit.
- In addition to conventional charging procedures, the following requirements shall be followed.
  - Ensure that contamination of different refrigerants does not occur when using charging equipment. Hoses or lines shall be as short as possible to minimise the amount of refrigerant contained in them.

- Cylinders shall be kept in an appropriate position according to the instructions.
- Ensure that the refrigerating system is earthed prior to charging the system with refrigerant.
- Label the system when charging is complete (if not already labelled).
- Extreme care shall be taken not to overfill the refrigerating system.

Prior to recharging the system, it shall be pressure-tested with the appropriate purging gas. The system shall be leak-tested on completion of charging but prior to commissioning. A follow up leak test shall be carried out prior to leaving the site.

- Before carrying out this procedure, it is essential that the technician is completely familiar with the equipment and all its detail. It is recommended good practice that all refrigerants are recovered safely. Prior to the task being carried out, an oil and refrigerant sample shall be taken in case analysis is required prior to re-use of recovered refrigerant.

**It is essential that electrical power is available before the task is commenced.**

- Become familiar with the equipment and its operation.
- Isolate system electrically.
- Before attempting the procedure, ensure that:
  - mechanical handling equipment is available, if required, for handling refrigerant cylinders;
  - all personal protective equipment is available and being used correctly;
  - the recovery process is supervised at all times by a competent person;
  - recovery equipment and cylinders conform to the appropriate standards.
- Pump down refrigerant system, if possible.
- If a vacuum is not possible, make a manifold so that refrigerant can be removed from various parts of the system.
- Make sure that the cylinder is situated on the scales before recovery takes place.
- Start the recovery machine and operate in accordance with instructions.
- Do not overfill cylinders (no more than 80 % volume liquid charge).
- Do not exceed the maximum working pressure of the cylinder, even temporarily.

## GENERAL INFORMATION

- 10) When the cylinders have been filled correctly and the process completed, make sure that the cylinders and the equipment are removed from site promptly and all isolation valves on the equipment are closed off.
- 11) Recovered refrigerant shall not be charged into another refrigerating system unless it has been cleaned and checked.
14. When removing refrigerant from a system, either for servicing or decommissioning, it is required to follow good practice so that all refrigerants are removed safely.

When transferring refrigerant into cylinders, ensure that only appropriate refrigerant recovery cylinders are employed. Ensure that the correct number of cylinders for holding the total system charge is available. All cylinders to be used are designated for the recovered refrigerant and labelled for that refrigerant (i.e. special cylinders for the recovery of refrigerant). Cylinders shall be complete with pressure-relief valve and associated shut-off valves in good working order.

Empty recovery cylinders are evacuated and, if possible, cooled before recovery occurs.

The recovery equipment shall be in good working order with a set of instructions concerning the equipment that is at hand and shall be suitable for the recovery of the flammable refrigerant.

Consult manufacturer if in doubt. In addition, a set of calibrated weighing scales shall be available and in good working order. Hoses shall be complete with leak-free disconnect couplings and in good condition.

The recovered refrigerant shall be processed according to local legislation in the correct recovery cylinder, and the relevant waste transfer note arranged. Do not mix refrigerants in recovery units and especially not in cylinders.

If compressors or compressor oils are to be removed, ensure that they have been evacuated to an acceptable level to make certain that flammable refrigerant does not remain within the lubricant. The compressor body shall not be heated by an open flame or other ignition sources to accelerate this process. Draining of oil from a system shall be carried out safely.

### Disposal

The environment and personal safety must be considered when disposing of this appliance. Please ensure the appliance is taken to a recycle center for safe recycling. DO NOT dispose of the appliance in land fill as the insulation and refrigerant gas contained in these appliances are flammable.



# INSTALLATION

## General Information

- Do not turn on the appliance if you have discovered damage to the appliance, cord or plug, if the appliance is malfunctioning or if there are signs of any other defect. Return the complete appliance to the vendor or to a certified electrician for inspection and/or repair. Always ask for original parts. The appliance (incl. cord and plug) may only be opened and/or repaired by properly authorized and qualified persons.
- Suggest to send the unit for professional maintenance periodically.
- **ONLY A LICENSED PROFESSIONAL IS ALLOWED TO DISMANTLE OR MODIFY THE APPLIANCE.**
- **THE APPLIANCE IS TO BE USED ONLY FOR ITS PRESCRIBED PURPOSE. ANY OTHER USE IS DEEMED TO BE A CASE OF MISUSE. THE USER/ OPERATOR, NOT THE MANUFACTURE WILL BE LIABLE FOR ANY DAMAGE OR INJURIES OF ANY KIND CAUSED AS A RESULT OF THIS.**
- Any person who is involved with working on or breaking into a refrigerant circuit should hold a current valid certificate from an industry-accredited assessment authority, which authorises their competence to handle refrigerants safely in accordance with an industry recognised assessment specification.
- Servicing shall only be performed on the grounds as recommended by the equipment manufacturer. Maintenance and repair requiring the assistance of other skilled personnel shall be carried out under the supervision of the person competent in the use of flammable refrigerants.

## Safety relating to refrigerant R290:

- Read these warnings carefully.
- This appliance contains the refrigerant R290. R290 is a refrigerant that complies with the relevant European Directives. Never perforate the refrigerant circuit. R290 is flammable (GWP3)!
- **Do not use means to accelerate the defrosting process or to clean, other than those recommended by the manufacturer.**
- **The appliance shall be stored in a room without continuously operating ignition sources (for example: open flames, an operating gas appliance or an operating electric heater).**
- **Do not pierce or burn any of the components of the cooling circuit of the unit.** Do not set light to the unit.
- The appliance shall be stored so as to prevent mechanical damage from occurring.
- **This appliance is designed for indoor use only. Only install, operate or store this appliance in a room with a floor area larger than 11m<sup>2</sup>.**
- **Be aware that the refrigerants may not contain an odour, which means you cannot smell leaks..**
- **Compliance with national gas regulations shall be observed.**
- **Keep ventilation openings clear of obstruction.**
- **The appliance shall be stored in a well-ventilated area where the room size corresponds to the room area as specified for operation.**



## PARTS

### FRONT

1. Control panel
2. Air vent
3. Caster
4. Carry handle
5. Air filter (air inlet)

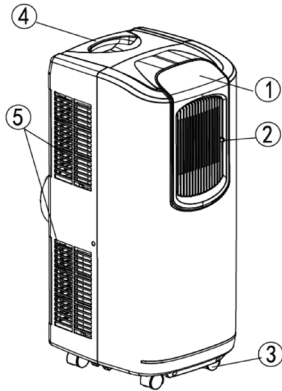

### BACK

6. Air filter (air inlet)
7. Exhaust air outlet
8. Drainage
9. Power cord storage

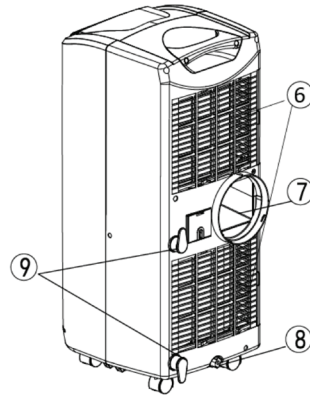

### ACCESSORIES

10. Flat Adaptor - for connecting the exhaust pipe and window spacer
11. Exhaust pipe
12. Round Adaptor - for connecting the appliance and the exhaust pipe
13. Remote control

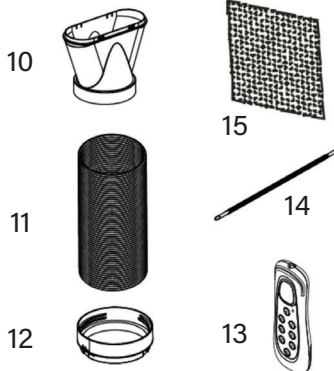

14. Drain tube for continuous drainage
15. Active carbon filter
16. Window spacer kit and fasteners

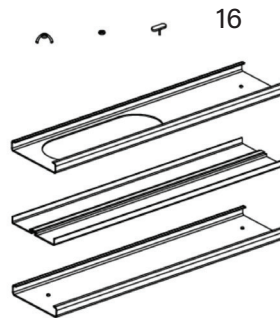

## INSTALLATION

This portable appliance can be moved from room to room as required.

Before using your appliance, the exhaust pipe and window spacer kit must be installed to allow the condensed heat to escape outside to the open air.

Using the included window spacer kit, follow the instructions below for the correct installation. Ensure that the distance between the appliance and the window spacer is at least 50cm.

### INSTALL THE ADAPTERS AND HOSE TO THE APPLIANCE:

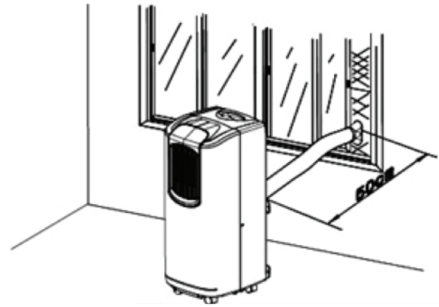
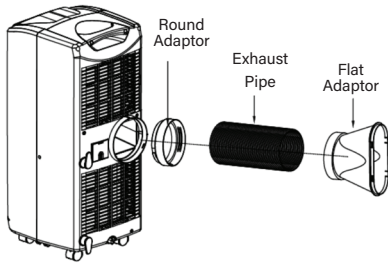

### INSTALL THE WINDOW SPACER KIT WARNING! TAKE CARE TO MAINTAIN PROTECTION AGAINST INTRUDERS

Adjust and position the spacer kit into the required opening, then slide the window towards the closed position retaining the spacer kit in place. Ensure that the spacer kit is held securely.

This same technique can be used for sliding sash windows.

(This Window Spacer Kit will not suit a 2.4m sliding door)

### ASSEMBLE THE WINDOW SPACER KIT

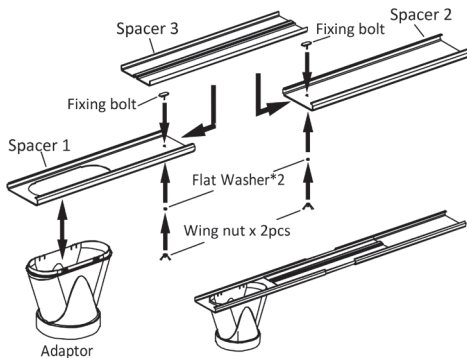

1. Insert the fixing bolt into the holes of Spacer 1 & 2.
2. Attach the washer and wing nut to the fixing bolt as shown and tighten them.
3. Insert Spacer 3 to Spacer 1 & 2 as shown, then tighten the wing nut again.
4. Insert the window adaptor into Spacer 1.

# EXHAUST PIPE

## MOUNTING

- Only use the exhaust pipe and fittings provided. Connect the exhaust pipe to the back of the appliance and then to the flat adapter which was previously installed in the window spacer kit.
- Avoid kinks and bends in the exhaust pipe as this will cause expelled moist air to build up causing the appliance to overheat and shut down. Fig. 1 & 2 show correct position
- The exhaust pipe may be extended from 300mm to 1500mm but for maximum efficiency use the shortest length possible.



### WARNING

The length and type of exhaust pipe has been designed for optimum performance of this appliance.

Only replace with same original exhaust pipe from the manufacturer.

Do not extend the exhaust pipe length.

WINDOW

Fig. 1

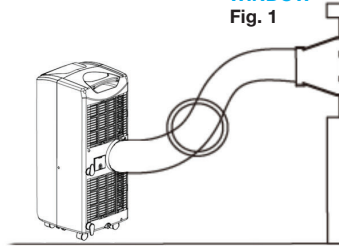

WINDOW

Fig. 2

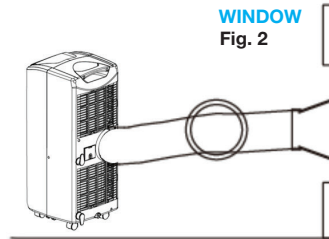

WINDOW

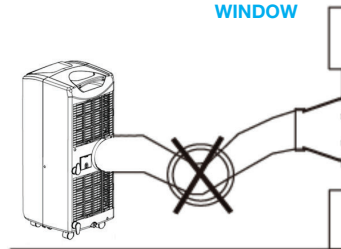

NO PIPE EXTENSION

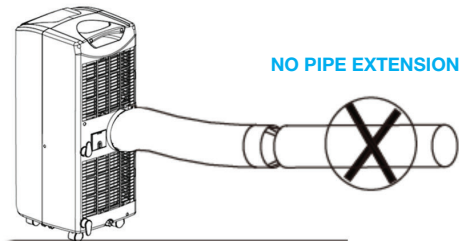

# CARBON FILTER

## INSTALLATION

This appliance is supplied with active carbon filters.

The activated carbon is charcoal that has been treated with oxygen to open up millions of tiny pores between the carbon atoms. It is used to get rid of unwanted odors (smoke, fumes, and animal odor). Please note, the carbon filter is not washable, its life span is variable and depends on the ambient conditions where the appliance is used.

The filter should be checked periodically and replaced if necessary (approximately every 6 months).

Carefully follow the steps below to install the active carbon filters.

1. Carefully remove the filter frame from the appliance.
2. Remove the filter retainer from the filter frame.
3. Remove the active carbon filter from its plastic bag.
4. Place the active filter onto the filter frame.
5. Re-attach the filter retainer to the filter frame, ensuring that the active carbon filter is held securely.
6. Re-insert the assembled filter frame back into the appliance.

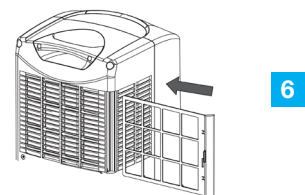
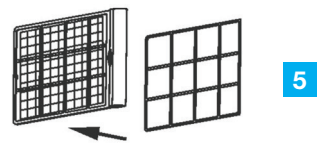
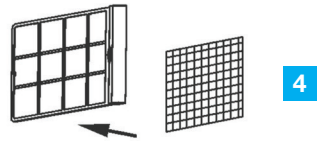
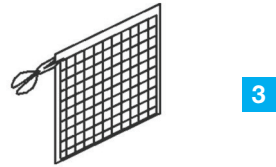
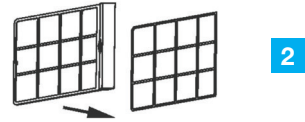
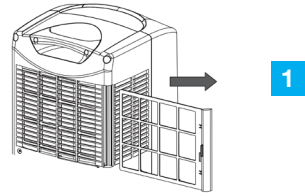

# CONTROL PANEL

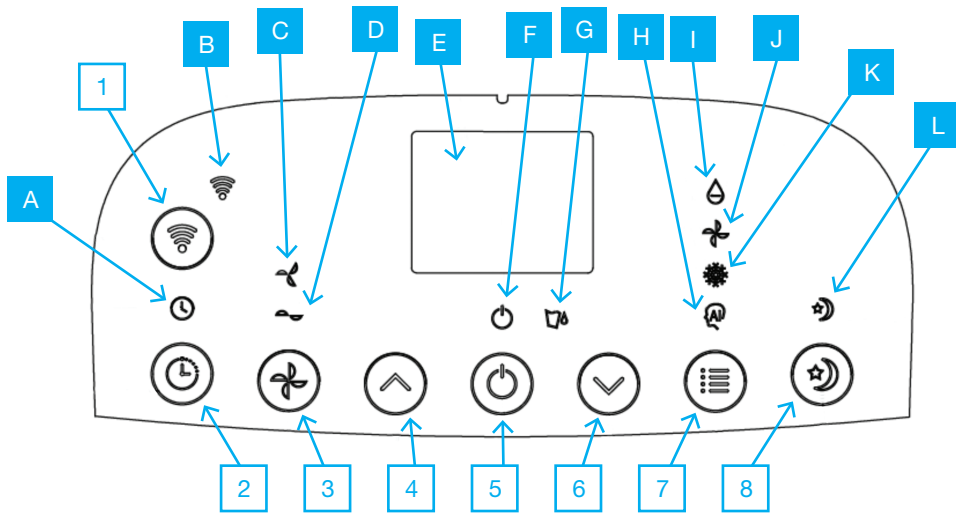

1. WiFi button
2. Timer button
3. Speed (ventilation) button
4. Temperature up button
5. ON/OFF (power) button
6. Temperature down button
7. Mode (function) option button
8. Sleep button

- A. Timer operation indicator
- B. WiFi indicator
- C. High ventilation indicator
- D. Low ventilation indicator
- E. Display window
- F. Compressor operation indicator
- G. "Full Water" indicator
- H. Automatic mode indicator
- I. Cooling mode indicator
- J. Dry (dehumidify) operation indicator
- K. Fan (ventilation) mode indicator
- L. Sleep mode indicator

## TURNING ON/OFF

1. Touch the ON/OFF button and the appliance will start in AUTO (automatic) mode.
2. Touch the ON/OFF button again, to turn the appliance Off.

Note; Wait at least 3 minutes before turning the appliance back On, once it has been turned Off.

### Automatic mode

In automatic mode, the appliance can cool or ventilate depending on the ambient temperature and set point adjustment. The appliance is preset as follows;

1. If the ambient temperature is greater than 23°C, the appliance will be in automatic cooling mode. (The default transition setting is 24°C). During this operation, the AUTO and COOL mode indicator will illuminate.
2. If the ambient temperature is less than or equal to 23°C, the appliance will be in automatic ventilation mode. During this operation, the AUTO and FAN mode indicator will illuminate.

Note; At the default setpoint of 24°C, the appliance starts cooling at 28°C (setpoint + 4°C). When the temperature reaches 26°C (setpoint + 2°C), it will then switch back to ventilation.

3. The display will indicate the room temperature from 0°C to 50°C.
4. The display window also shows the ambient room temperature from 0°C to 50°C.

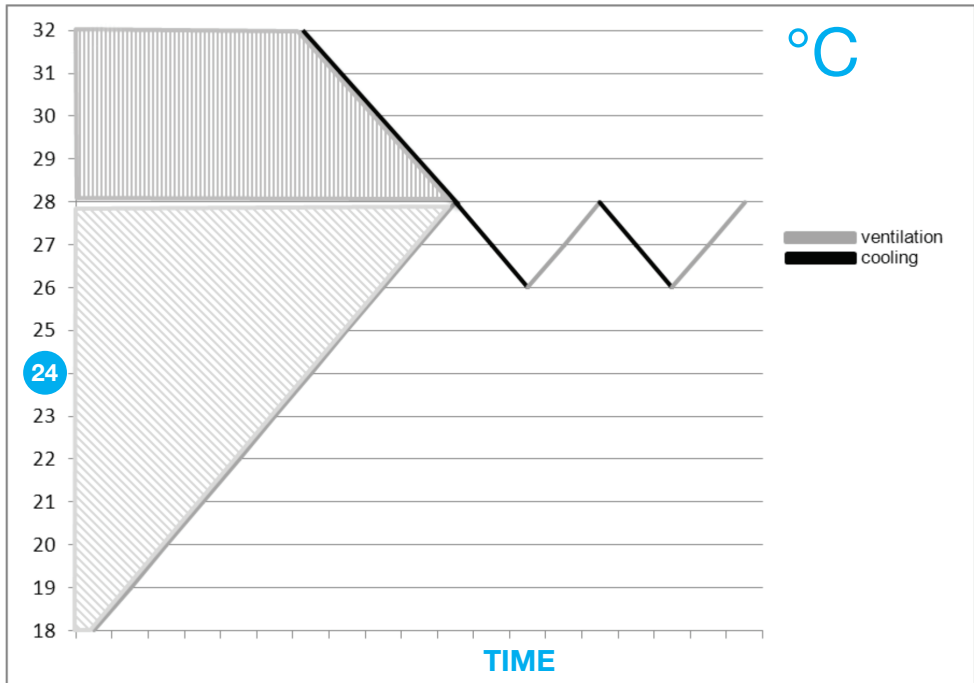

# SETTINGS

## Setting mode/function

Touch the MODE button to select the required operating mode: Cooling or Fan (Ventilation).

The corresponding indicator of your selected mode will illuminate.

## Setting temperature

1. Touch the 'Temperature up' or 'Temperature down' button to regulate the temperature that you desire (range: 18-32°C).
2. The display window will show the temperature you set as you press 'Temperature up' or 'Temperature down' button. Otherwise, it will always show the ambient temperature (range: 0°C to 50°C).

## Setting ventilation speed

1. Touch the SPEED button to choose the ventilation speed required, high or low. The corresponding setting and mode will illuminate at the same time.
2. If the appliance is in AUTO mode, the ventilation speed is automatically set according to the ambient temperature. The corresponding indicator lights will illuminate at the same time and the speed switch will be deactivated.

## Setting timer

1. Touch the TIMER button to set the operating hours required. (1 to 24 hours, the timer mode will illuminate). When the set time has been reached, the appliance will turn off automatically.

The display window will indicate the hour/s set with each touch of the timer button.

If the timer button is not pressed, the appliance will operate continuously. By touching the timer but without turning on the other functions, you can PRESET the time for the appliance to work. For example, if you press the timer to '2', the appliance will work automatically after 2 hours.

## Sleep function

1. In cooling mode, by pressing the SLEEP button, the set temperature will increase 1°C at the 1st hour, another 1°C at the second hour, then keeps at that temperature.
2. In sleep mode, the ventilation will keep at low speed. Re-press the SLEEP button, the setting temperature and ventilation speed will return to the pre-selected one.
3. The appliance will shut down automatically after the SLEEP function running for 12 hours.

4. Please note, the sleep mode is not available while the appliance is operating in ventilation, dehumidification or auto modes. Sleep mode is only available in the cooling mode.

## Dehumidify (DRY) mode

The appliance will default to low speed when dehumidify (dry) mode is selected. While operating in this mode, humidity is extracted from the air and collected. When the appliance is operating in Dehumidify (Dry) mode, the temperature cannot be adjusted and the ventilation will be fixed at low speed. Humidity is extracted from the air and collected in the internal water tank. Once the tank is full, the compressor motor will cut-out automatically. At the same time, the 'Water Full' indicator will illuminate and an alarm will sound. Refer to page 13 for instructions on how to empty the internal water tank and connection for continuous drainage.

All the above functions can also be performed with the supplied remote control. This remote control requires 2 x AAA batteries to operate (not supplied)



## Self-diagnosis

The appliance is fitted with a self-diagnosis function. If there is a problem, the display will show the fault code 'E1' or 'E2'.

Please contact Customer Service for assistance. Please see page 2 for details.

Do not attempt to dismantle this appliance.

## WiFi function

Please refer the QR CODE on the front page for WiFi setup.

## AIR FLOW

Adjust the air flow direction by manually moving the outer vent louvers 'Up' or 'Down'.

### IMPORTANT!

1. To extend the life of the compressor, it is recommended to wait at least 3 minutes before turning the appliance back On, once it has been turned Off.
2. The cooling system will turn off if the ambient temperature falls below the set level. However, the ventilation will continue to operate at the set level. Once the ambient temperature rises above the selected level, the cooling system will resume operation.

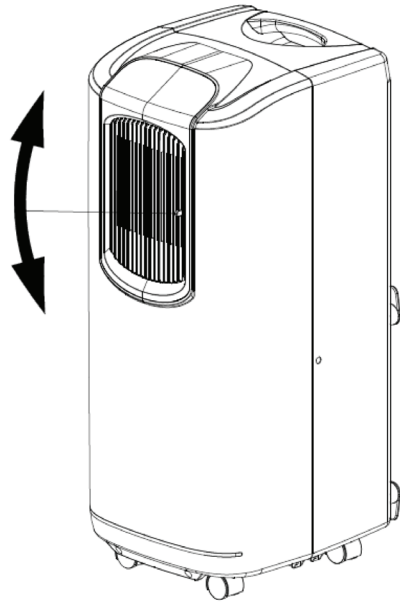



## DRAINAGE

During normal operation of this appliance, moisture from the air will be collected in the internal water tank and will require emptying periodically.

If the water tank fills to the maximum level, the 'Water Full Indicator' will illuminate, an alarm will sound, and the compressor will turn off.

Press any button to turn Off the alarm sound.

To continue operation, the water tank will require emptying by using the following instructions.

1. Turn off the appliance and avoid moving it when full.
2. Position a container (a water tray for example) underneath the drain hole.
3. Remove the drain knob and rubber plug from the drain hole and allow the water to drain out.
4. When the container is almost full, replace the rubber plug in the drain hole and empty the water tray.
5. Repeat until the appliance is emptied.
6. Replace the rubber plug and tighten the drain knob firmly.
7. Switch on the appliance - the full water or compressor operating indicator should not be flashing.

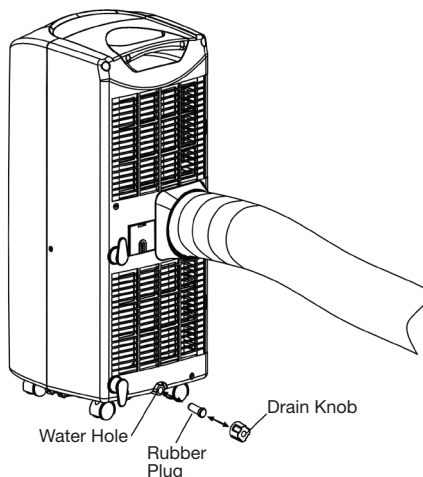

Should you prefer to use the appliance without having to empty the tank every so often, proceed as follows:

- Remove the drain knob and rubber plug and retain for future use.
- Connect the drain tube supplied to the water outlet as shown and locate the other end into a drain.
- The drain tube may be extended by adding an extension tube and using a suitable connector.

### Please note

1. The drain must be at a lower level than the drain hole on the appliance.
2. Flashing 'Water Full' indicator will not function in this mode of drainage.
3. If you want to extend the water tube, you can connect it with another tube (OD: 18mm). NOT supplied.

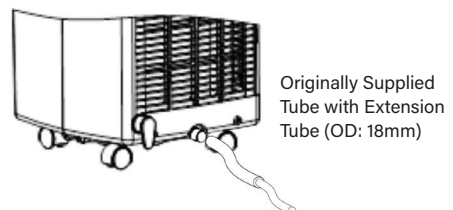
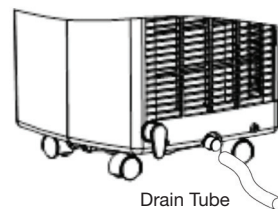
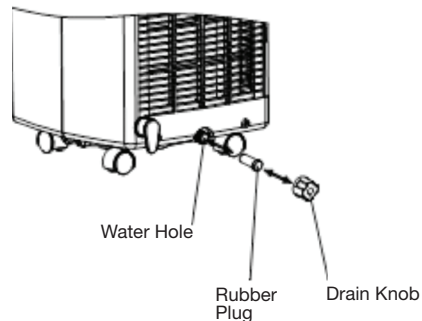

## MAINTENANCE

For personal safety, always unplug the appliance from mains power prior to cleaning.

To maximize the efficiency of this appliance, ensure that it is cleaned regularly following these simple steps.

### Cleaning the housing

Use a soft cloth, dampened with water only to wipe down the outer case.

Do not use aggressive chemicals such as petroleum based, general cleaning detergents or chemical treated cloths as these may damage plastic.

### Cleaning the filter

Regularly clean the filter/s by gently tapping or using a vacuum cleaner to remove accumulated dust or debris.

Rinse under warm running water and thoroughly dry before reinstalling.

Important!

Never operate the appliance without filter/s installed.

### End of season storage

- Remove any accumulated water within the appliance by following the instructions under the heading 'DRAINAGE'
- Turn on the appliance, and operate the on ventilation for a minimum of 2 hours to dry out the internal components.
- Clear or replace the filter/s

Unplug and store the power cord as shown under the heading 'PARTS'

- Cover and store in a room with a floor area larger than 11m<sup>2</sup>.

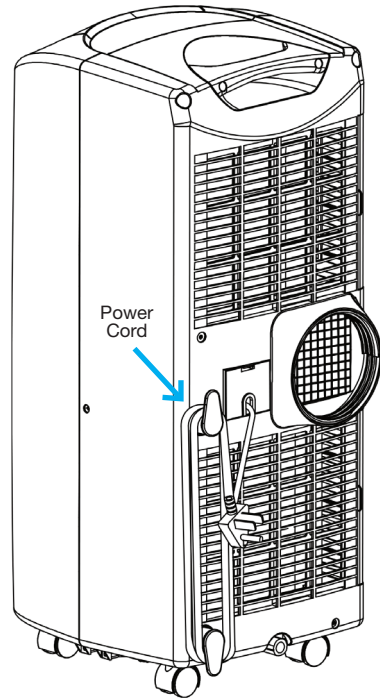

## FAULT CHECK LIST

FAULT	CAUSE
<b>The appliance does not turn On.</b>	<p>Is the appliance plugged in or turned On?                      Is there a power failure?                      Is the 'Water Full' indicator flashing? Empty if required.                      Is the room temperature below the set temperature?</p>
<b>The appliance is not cooling as is should.</b>	<p>Is the appliance in direct sunlight? Close curtains if necessary.                      Are there too many windows or doors open?                      Are there too many people in the room?                      Is there another heat source in the room?</p>
<b>The appliance is not operating as it should.</b>	<p>Is the filter dusty, contaminated?                      Is the air intake or output blocked up?                      Is the room temperature below your selected temperature?</p>
<b>The appliance is excessively noisy.</b>	<p>Is the appliance on an uneven surface creating a vibration?                      Reposition if necessary.</p>
<b>The compressor doesn't run.</b>	<p>The compressor overheat protection function may have activated. Turn the appliance Off, and wait for the compressor to cool down and try again.</p>

**Only a licensed professional is allowed to dismantle the appliance.**

**Suggest to send the appliance for professional maintenance periodically.**

# Excelair

By Excelsior

## SPECIFICATIONS

ITEM No	EPA58023W
Cooling capacity	2.3 kW
Power/Ampere consumption* (Cooling)	920W/4.2A
Air volume (max. speed)	360m <sup>3</sup> /h
Humidity removal capacity	0.97L/h
Power supply	220 - 240V/50Hz
Compressor	Rotary
Refrigerant	R290/ 220g
Fan speed	2
Timer	24 Hours
Working temperature	Cooling: 18 ~ 32°C
Exhaust pipe	Ø 150x1500mm
Net Weight	23Kg
Dimension	305 x 387 x 752 mm (WxDxH)

### REMARK:

1. The data marked with "\*" may vary for technical reasons: for greater precision, please refer to the rating label placed at the back of the appliance.
2. Measuring condition for above is: Cooling - DB= 35°C , WB= 24°C
3. Current & Fuse: F10AL250V or T10AL250V
4. Test conditions for data label information is per Safety Regulation: AS/NZS60335-2-40

## For any queries or assistance call

**Customer Service**  
(Australia Only)



**1300 174 876**

Hours of operation:

Monday to Friday 8am - 5pm EST

### Do not return to place of purchase.

Keep your purchase receipt, this will be required to make any claims under the 24 month warranty.